



**LOWFLOW**  
a division of Jordan Valve

3170 Wasson Road • Cincinnati, OH 45209 USA  
Phone 513-533-5600 • Fax 513-871-0105  
lowflow@richardsind.com • www.lowflowvalve.com

## I & M 8000 Series

### Installation & Maintenance Instructions for 8000 Series Low Flow Control Valves

Warning: Low Flow Regulators must only be used, installed and repaired in accordance with these Installation & Maintenance Instructions. Observe all applicable public and company codes and regulations. In the event of leakage or other malfunction, call a qualified service person; continued operation may cause system failure or a general hazard. Before servicing any valve, disconnect, shut off, or bypass all pressurized fluid. Before disassembling a valve, be sure to release all spring tension.

#### Please read these instructions carefully!

Your LowFlow/Jordan product will provide you with long, trouble-free service if it is correctly installed and maintained. Spending a few minutes now reading these instructions can save hours of trouble and downtime later. When making repairs, use only genuine LowFlow Valve parts, available for immediate shipment from the factory.

### Ideal Installation Schematic

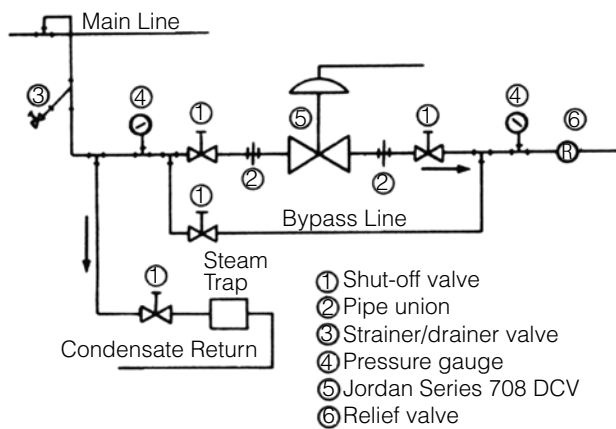

### Preferred Installation

- To control very low flow rates, Mark 8000 control valves are often provided with trims having very small clearances. To keep this trim functioning properly, it is essential that the fluid flowing through the valve be clean.
- To protect the valve from grit, scale, thread chips and other foreign matter, ALL pipelines and piping components should be blown out and thoroughly cleaned before the installation process begins.
- Shutoff valves, pressure gauges, and by-pass piping should be installed as indicated in the *Ideal Installation Schematic* to provide easier adjustment, operation and testing.
- A line strainer should be installed on the inlet side of the valve to protect it from grit, scale, and other foreign matter. A 0.033 perforated screen is usually suitable for this purpose. Line strainers are available from Jordan Valve.
- For best control, 3'-0" straight sections of pipe

- should be installed on either side of the valve.
- In preparing threaded pipe connections, care should be exercised to prevent pipe-sealing compound from getting into pipelines. Pipe sealing compound should be used sparingly, leaving the two end threads clean. Jordan Valve uses, and recommends, thread sealer Teflon ribbon.
- The flow arrow on the valve body must be pointed in the direction of the flow. Ideally the valve should be installed in the highest horizontal line of piping to provide drainage for inlet and outlet piping, to prevent water hammer, and to obtain faster response.
- If possible, install a relief valve downstream from the valve. Set at 15 psi above the control point of the valve.
- In hot vapor lines, upstream and downstream piping near the valve should be insulated to minimize condensation.
- Evaluate inlet and outlet pipe friction losses and velocities to decide when smaller outlet piping might cause excessive back pressure. When required, a standard tapered expander connected to the outlet of the valve is recommended.
- When surges are severe, a pipe accumulator is recommended.
- On steam control applications, install a steam trap with sufficient capacity to drain the coil or condenser. Be sure to have a good fall to the trap, and no backpressure. Best control is maintained if the coil or condenser is kept dry.

### Trouble Shooting

#### • Erratic control

- Oversizing can cause cycling or hunting - recalculate the size required
- Undersizing can cause the control point to drop off under peak loads - increase the trim size
- Inlet pressure to the valve may be varying significantly and the controller may not be following it - adjust controller
- Control loop may require an equal percentage trim if higher rangeabilities are being utilized
- Controller may not be properly adjusted
- Steam traps may need reconditioning

7. Safety relief valves may be leaking
8. Valve stroke may be out of adjustment or there may be foreign matter in the valve preventing full plug movement
9. Slowly open the inlet shutoff valve.
10. Slowly open and close the outlet shutoff valve several times. This fully strokes the valve to insure satisfactory operation.

• **Insufficient Flow**

1. Check shutoff valves to be sure they are fully open
2. Inlet pressure to the valve may be insufficient to provide the needed flow - check the inlet pressure with a pressure gauge
3. Strainers should be checked for clogging - blow-down if needed
4. Steam traps may need reconditioning
5. Dirt in the trim may prevent the valve from passing its full capacity
6. Diaphragm failure in reverse acting (air-to-open) actuators would prevent the valve from properly stroking open
7. Insufficient air pressure to reverse acting (air-to-open) actuators would prevent the valve from properly stroking open.

• **Overpressure (outlet)**

1. Dirt in the trim may be preventing the valve from shutting off
2. Diaphragm failure in direct acting (air-to-close) actuators would prevent the valve from properly stroking closed
3. Insufficient air pressure to direct acting (air-to-close) actuators would prevent the valve from properly stroking closed
4. Incorrect actuator spring adjustment in direct acting (air-to-close) actuators would prevent the valve from properly stroking closed.

• **Leakage**

1. Excessive pressure drop across the valve could prevent the valve from shutting off properly. Check the catalog ratings for the maximum allowable pressure drop for your trim, action and actuator.

---

## Start-Up Procedure

---

1. Be sure that the action of the control valve and of the controller are such as to give the desired results. See part D to change the valve action if necessary.

| Controller Action                              |                                |  |
|--|--------------------------------|--|
| If an increase in pressure or temperature must | And the action of the valve is | And the action of the controller must be |
| close valve                                    | air to close                   | direct                                   |
| close valve                                    | air to open                    | reverse                                  |
| open valve                                     | air to close                   | reverse                                  |
| open valve                                     | air to open                    | direct                                   |

2. The control valve has been pre-set by Low Flow Valve. However, finer adjustments may be required to compensate for pressure drop conditions of the application.
3. With the inlet, outlet, and by-pass shutoff valves closed, and no pressure in the downstream line, fully open the shutoff valve. Slowly open the inlet valve just enough to start flow through the control valve. Increase flow gradually by slowly opening the inlet shutoff valve. Do not fully open the inlet valve until you are sure the controller and control valve have control of the system. Usually, the handwheel on the inlet valve will turn freely when this point is reached.
4. To shut off the line fluid, close the inlet shutoff valve first, followed by the outlet shutoff valve.

---

## Maintenance

---

**Warning:** Be sure that there is no pressure in the valve before loosening any fittings or joints. The following steps are recommended:

1. Close inlet shutoff valve and by-pass valve.
2. Allow pressure to bleed off downstream.
3. When inlet pressure gauge shows that there is no pressure in the valve, close the outlet shutoff valve.

TO REDUCE MAINTENANCE TIME, REFER TO PROPER FIGURE AND FOLLOW STEPS INDICATED BELOW FOR APPLICABLE MAINTENANCE OPERATION.

| Proposed Maintenance  | Follow Steps     |
|---|------------------|
| Renewing Valve Stem Packing   | Section 1        |
| Valve Disassembly - Inspect Parts - Replace Valve Plug or Seat Ring | Section 2        |
| Valve Reassembly  | Section 3        |
| Actuator Spring Preload Adjustment                                  | Section 4        |
| Actuator Maintenance  | Section 5        |
| Changing Valve Action   | Reversing Action |

### Section 1: Packing Replacement

*Renew the stem packing whenever there is leakage that cannot be stopped by a light adjustment to the packing flange. Additional rings can be added to the packing set to overcome minor packing leakage and provide for additional adjustment space. This can be done without dismantling the valve.*

1. Remove the actuator from the bonnet. (See VALVE DISASSEMBLY, SECTION 2).
2. Completely remove all of the old packing (6) and discard. Clean the valve stem (33) and packing box thoroughly. If necessary, the valve stem may be dressed with a very fine Crocus cloth, but generally it is best not to as the stem has a fine machined finish. Use an approved non-residue forming solvent for cleaning. Wipe dry with a clean cloth.
3. Insert a new packing set in the packing box. Press each ring down firmly into place with a tube.
4. After the packing is installed, assemble the packing adapter (7), and packing nut (11). Tighten the nuts hand-tight.

5. The final packing adjustment should be made with the valve pressurized and the packing tightened just enough to stop any leakage, while stroking the valve. Excessive tightening could cause the stem to stick and result in improper valve operation due to high friction forces.

## Section 2: Actuator to Valve Disassembly

### • Direct Acting Actuator: ATC (air-to-close)

1. Shut off pressure to actuator, and remove the supply tubing from the actuator case.

### • Reverse Action Actuator: ATO (air-to-open)

1. Apply approximately 6 psig air pressure to the actuator to lift the plug off the seat.
2. Remove the actuator from the valve as follows: loosen the two stem nuts (36) and move them down the stem (33). Lock these nuts together. Remove the two nuts (31) that secure the support legs (16B) to the actuator mounting flange (9). Using a wrench on the nuts and on the flats of the stem adapter (46), turn the valve stem (while holding the stem adapter in place) until the stem disengages. The actuator will now be free from the valve. **Caution: Do not lose the spacers (38) – they will disconnect from the support legs when the actuator is removed from the mounting flange.**

## BODY & BONNET DISASSEMBLY

1. Remove packing nut (11) and bonnet nut (8).
2. Remove stem nuts (36) from stem (33) and pull up on stem before unthreading bonnet (2) from body (4).
3. Remove the stem (33) from the bonnet (2).
4. With a socket wrench, remove the seat (35) from the body.
5. Soft seats are disassembled by removing the soft seat assembly (48) from the body.
6. Clean all parts with an approved, non-residue forming solvent. Remove encrusted material with a very fine Crocus or aluminum oxide cloth. However, do not use these abrasives on the seating surface or the trim surface (that portion of the plug that enters the seat bore). The machining tolerances on these surfaces are so closely controlled that you might change the valve's flow characteristics.
7. Inspect all parts and replace any badly worn or damaged parts.

Do not attempt to resurface seating surfaces of the plug or seat. Seat and plugs are only sold in factory matched sets. It is always advisable to replace seals and gaskets.

## Section 3: Valve Reassembly

### • Body

1. Lubricate the hard seat (35) or soft seat (48) threads with a suitable lubricant such as NO-LOK and thread the seat into the body (4). Torque to 20 ft-lbs (240 in-lbs).
2. Guided Trim: coat the guided portion of the plug (34) with Molykote G-Rapid Spray lubricant or an equivalent light lubricant suitable for your service. Assemble the plug to the stem.

3. Insert the stem (33) and plug (34) into the bonnet (2) and install the packing as described in Section 1.
4. Plastic Valves Only: place the o-ring (49) around the base of the bonnet.
5. Pull the stem up in the bonnet before threading the bonnet (2) into the body (4).
6. Push down on the stem to allow the plug (34) to center itself in the seat (35).
7. Reassemble the two set nuts (36) onto the stem (33) threads and lock the two nuts together.
8. If the actuator is reverse acting (ATO), apply approximately 6 psig air pressure to the actuator.
9. Install the spacers (38) onto the support legs (16B) and insert the support legs into the actuator mounting flange (9). Thread the stem (33) into the stem adapter (46) at least four complete turns, holding the stem adapter with a wrench to prevent it from turning. If the support legs are still not in full contact with the actuator mounting flange, thread the stems together until full contact is achieved and install nuts (31) onto the support legs and tighten.
10. Thread both stem nuts (36) up and tighten them against the stem adapter (46).

## Section 4: Actuator Spring Pre-Load Adjustment (Bench Setting)

1. The two stem nuts (47) should be loosened and threaded down the stem and then locked together.
2. A regulated air supply must be provided to the actuator. Connect the air to the lower actuator case (16A) for reverse action or to the upper actuator case (17A) for direct action actuators.
3. Standard actuators have ranges of either 3-15 psig or 6-30 psig. The range is stamped on the valve nameplate. These instructions will assume that the range is 3-15. If yours differs, substitute the appropriate pressure where these instructions refer to 3 psig.

### • Direct Acting Actuator: ATC (air-to-close)

1. The spring preload adjustment may be made with or without pressure in the valve body.
2. Spring preload is adjusted by threading the stem adapter (46) into the actuator stem (22). Keep the actuator stem from turning with a wrench and turn the stem adapter. Threading the stem adapter into the actuator stem increases preload while threading out decreases preload.
3. Slowly increase the air pressure up to 3 psig while observing the stem for movement. Correct spring preload is when the valve stem starts to move when the actuator pressure reaches 3 psig.

If movement starts before 3 psig, increase the preload; if movement starts at a pressure higher than 3 psig, decrease the preload.

### • Reverse Acting Actuator (ATO (air to open)

1. In an ATO actuator, the valve plug is closed by the actuator spring force which operates against the stem thrust created by the inlet pressure pushing up on the plug and stem. If the spring preload adjustment is made without pressure in the valve body,

additional preload may be needed to overcome the effects of this thrust when the control valve is placed in service. The amount of additional preload will be dependent on the size of the seat orifice and the inlet pressure. For the smallest trims and low pressures, it will be negligible. For the largest trim it could be significant. The catalog lists the maximum pressure that the valve is capable of shutting off against with a 3 psig preload. If higher pressures are needed, then a positioner should be used.

2. Spring preload is adjusted by threading the stem adapter (46) into the actuator stem (22). Keep the actuator stem from turning with a wrench and turn the stem adapter. Threading the stem adapter into the actuator stem decrease preload when the valve stem starts to open when the actuator pressures reaches 3 psig.
3. Slowly increase the air pressure up to 3 psig while observing the stem for movement. Correct spring preload is when the valve stem starts to open when the actuator pressure reaches 3 psig.
4. If movement starts before 3 psig, increase the preload; if movement starts at a pressure higher than 3 psig, decrease the preload.
5. After the preload is set, lock the travel scale indicator nuts (46) against the actuator stem. The valve travel scale indicator (24) may require adjustment relative to the indicator (37).

## Section 5: Actuator Maintenance

### Disassembly and Inspection of Actuator

1. Close inlet and outlet stop valves. Operate system on bypass, if necessary.
2. Shutoff operating medium and relieve pressure from diaphragm by disconnecting tubing at diaphragm case.
  - **Direct Acting Actuator (air to close)**
    1. Disconnect the actuator stem (22) from the stem adapter (46) by loosening the two adapter stem nuts (47), moving them down the stem adapter and locking the two nuts together. With appropriate tools holding the adapter stem nuts and the flats of the stem adapter, thread the stem adapter out of the actuator stem. Grip actuator stem and remove hex bolt (20), thread seal (13), diaphragm washer (19), diaphragm (12), diaphragm plate (18) and springs (32).
  - **Reverse Acting Actuator: ATO (air to open)**
    1. Remove actuator from body (refer to Section 2). Remove the actuator case bolts (20) and nuts (45) that hold the upper case (17A) to the lower case (16A), and remove the upper actuator case. Remove springs (32), hex bolt (20), diaphragm plate (18), diaphragm washer (19), and thread seals (13).

2. Check actuator stem o-ring (14), remove actuator stems (22), unscrew the gland nut (44) from the gland (43) and remove the o-ring.
3. Clean all parts with an approved, non-residue forming solvent. Remove encrusted material with fine emery paper or very mild aluminum cloth. Inspect all parts for excessive wear and/or damage. Replace any worn or damaged parts.

### Reassembly of Actuator

After all parts have been thoroughly cleaned and inspected, reassemble the actuator.

1. Greasing the o-ring, insert the actuator stem (2) through the gland (43). Thread on, and tighten gland nut (44).
  - **Direct Acting Actuator (air to close)**
    2. Place springs (32) on lower actuator case (16A). Place diaphragm plate (18) on springs, making sure springs are nested on the punched bosses. Install the diaphragm (12) with the holes lined up with the bolt holes in the lower actuator case. Place the diaphragm washer (19) on diaphragm (12). Install the thread seal (13) on the hex bolt (20) and thread hex bolt into the actuator stem (22) and tighten.
  - **Reverse Acting Actuator: ATO (air to open)**
    2. Install thread seal (13), diaphragm washer (19), diaphragm (12) and diaphragm plate (18), and tighten down the hex bolt (2). Place the springs (32) on diaphragm plate (18) so that the springs are nested in the punched bosses.
    3. Place upper actuator case (17A) on diaphragm (12), lining up with the bolt holes.
    4. Replace four bolts (20) and nuts (45) 90° apart and tighten fingertight. Replace the remainder of the bolts and nuts and tighten evenly alternating across the actuator case.
    5. Thread the stem adapter (46) into the actuator stem (22), and reinstall the actuator onto the body assembly. (Refer to Section 3: Valve Reassembly (points 6-10).
    6. Adjust spring load. Refer to Section 4: Actuator Spring Pre-Load Adjustment.

---

## Reversing Action

---

*CHANGING THE VALVE ACTION FROM DIRECT TO REVERSE ACTING OR FROM REVERSE TO DIRECT ACTING.*

The action of the Series 8000 control valve is changed by reversing the action of the actuator.

1. Disassemble the actuator. Refer to Section 5.
2. Reassemble the actuator with the desired action. Refer to Section 5.

**Use only Low Flow replacement parts.**

Low Flow Valves are ruggedly built, carefully assembled to accurate dimensions, and individually tested for performance. A complete stock of finished parts is maintained ready for immediate shipment. Low Flow valves are held to the close tolerances required for precision valves. The use of any other parts will affect valve performance.

If desired, Low Flow Valve will promptly repair your regulator at a reasonable cost. To return a valve for inspection and/or repair, please contact our customer service department for a Return Authorization Number. Phone toll-free at 1-800-543-7311. If preferred, you may fax us at 513-871-0105.

When ordering spare parts, first make a note of the following information on the valve's nameplate:

- serial number
- model number and size
- body material and end connections
- range
- seat and seal materials

## Direct Acting (ATC)

• **35M Actuator**

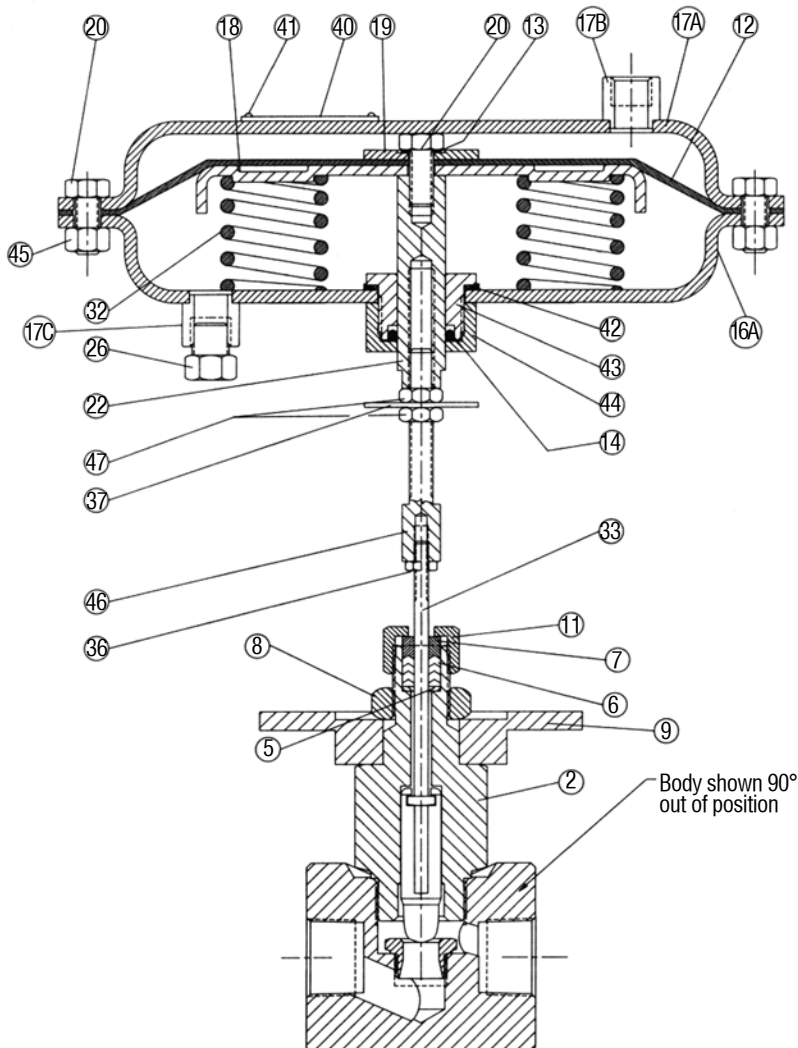

**Soft Seat Option**

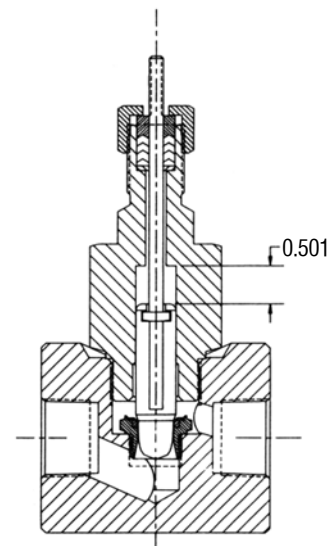

## Reverse Acting (ATO)

• **35M Actuator**

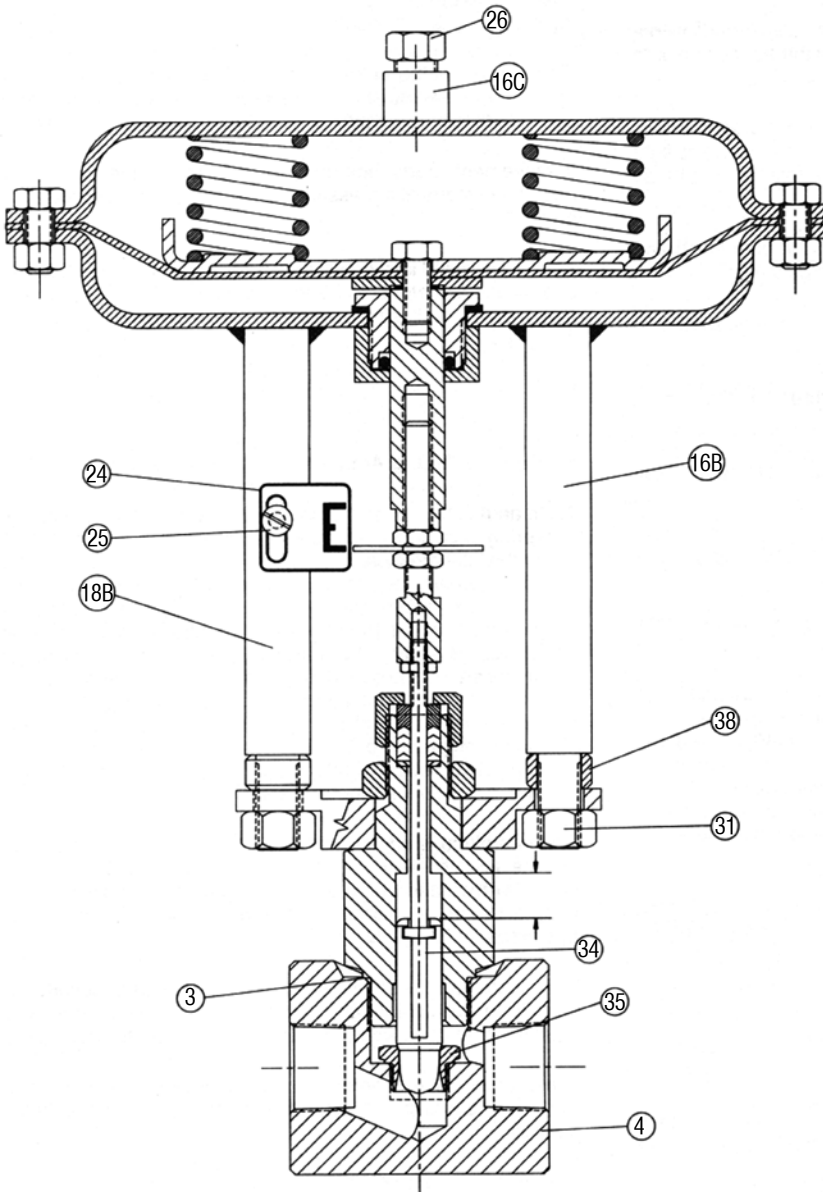

| I No. | Description                   | Qty |
|-------|-------------------------------|-----|
| 2     | Bonnet                        | 1   |
| 4     | Body                          | 1   |
| 5     | Retaining Washer              | 1   |
| 6     | Packing Set                   | 1   |
| 7     | Adaptor                       | 1   |
| 8     | Bonnet Nut                    | 1   |
| 9     | Act. Mounting Flange          | 1   |
| 11    | Packing Nut                   | 1   |
| 12    | Diaphragm                     | 1   |
| 13    | Thread Seal                   | 1   |
| 14    | O-Ring                        | 1   |
| 16    | Actuator, Lower Case Assembly | 1   |
| 16A   | Actuator, Lower Case          | 1   |
| 16B   | Support Leg                   | 2   |
| 16C   | Bushing                       | 1   |
| 17    | Actuator, Upper Case Assembly | 1   |
| 17A   | Actuator, Upper Case          | 1   |
| 17B   | Bushing                       | 1   |
| 18    | Diaphragm Plate               | 1   |
| 19    | Washer Diaphragm              | 1   |
| 20    | Hex Bolt                      | 9   |
| 22    | Stem, Actuator                | 1   |
| 24    | Scale, Travel                 | 1   |
| 25    | Screw                         | 1   |
| 26    | Vent                          | 1   |
| 31    | Nut                           | 2   |
| 32    | Spring                        | 6   |
| 33    | Stem                          | 1   |
| 34    | Plug                          | 1   |
| 35    | Seat                          | 1   |
| 36    | Nut                           | 2   |
| 37    | Washer                        | 1   |
| 38    | Spacer                        | 2   |
| 40    | Name Plate                    | 1   |
| 41    | Drive Screw                   | 2   |
| 42    | Gasket                        | 1   |
| 43    | Gland                         | 1   |
| 44    | Gland Nut                     | 1   |
| 45    | Nut                           | 8   |
| 46    | Stem Adaptor                  | 1   |
| 47    | Nut                           | 2   |
| 48    | Soft Seat Assembly            | 1   |
| 49    | O-Ring (Plastic Valves)       | 1   |