

Mark 16IQ Series

Smart Valve Positioners

Overview

The Mark 16IQ is the "Smart" side mounted positioner of choice for Steriflow Mark 978 Control Valve models 978SP and Mark 978 INLINE model NSP. This compact, rugged unit offers comprehensive diagnostics and high level customization with the convenience of push buttons for in situ configuration or use of a HART® communicator.

Operation & Design

The primary module of the Mark 16IQ is the electronic board comprised of the microprocessor, along with the indicating and control elements. The unit is designed so that optional modules for alarms and position feedback are easily plugged in or snapped on.

The current command (which typically serves as the power supply to the instrument) is compared to the internal position feedback signal. By comparing the input and feedback signals, an adaptive controller determines the positioning signal, which follows an optimized algorithm. The parameters for this algorithm are determined from valve and actuator characteristics analyzed during initialization and as modified during the real-time performance of the actuator. The MK16IQ will identify and optimize each valve's specific performance characteristics.

The positioning signal controls piezo electric solenoid valves which respond based on the size of the control deviation. The resultant actuator pressure can be modified to adapt the response time to the actuator size.

Two binary inputs are standard and allow the logical linkage of the binary input signals with alarm reports, or positioning the actuator at its fail-safe position.

If the "standard" Mark 16IQ is chosen with your valve selection, configuration and diagnostic information can be accessed via PC or HART® handheld communicator. Additionally, all settings and diagnostic information can be called up locally at the positioner via the push buttons located inside the cover of the unit. The Analog Positioning Module supplies an analog 4-20 mA feedback signal, while the Binary Module supplies stroke and alarm reports.



Steriflow Valve offers the MK16IQ in three primary configurations:

- Mark 16IQ-B 'Basic' Version: smart positioner without HART® protocol with gauge block and FM Approval (IS) for Class I, Div. 1 locations. Specify part number 16184.
- Mark 16IQ-S 'Standard' Version: same basic unit but with HART® protocol capability. Specify part number 98877.
- Mark 16IQ-FF 'Foundation Fieldbus™': for advanced diagnostics with digital communication and control.
- Other configurations available - contact factory for Profibus, limit switch module, alarm module and other accessory ordering information.

Features & Configurations

The Mark 16IQ is a side-mounted “smart” valve positioner with superior accuracy, long-term reliability and ease of use. Even with the ‘Basic’ configuration, it’s still packed with useful features such as:

- LCD digital display
- Push-button configuration
- Directly adaptable to both linear and rotary valves
- Loop powered by 4-20 mA signal as with standard I/P positioners
- Split range functionality
- Zero air consumption in standby mode – only uses air supply when repositioning valve.
- 175°F ambient temperature limit
- Linear, equal percentage or user-determined flow characteristics
- IP 65/NEMA 4X enclosure protection
- Stroke limitation
- Tight shutoff feature

- Multiple solenoids to minimize overshoot and dead-band
- Automatic initialization procedure

When provided with HART® protocol, the Mark 16IQ can be configured in a variety of ways:

- utilizing the keys on the unit (found beneath the cover)
- by means of a HART® communicator
- with a PC using SIPROM PS2 Software

Whether you select the ‘Basic’ option with its advanced configuration features, the ‘Standard’ option with its HART® protocol for enhanced diagnostics or the fully digital fieldbus options, coupling the MK16IQ with another Steriflow Control Valve will give you world-class performance and help keep you in control of your process.

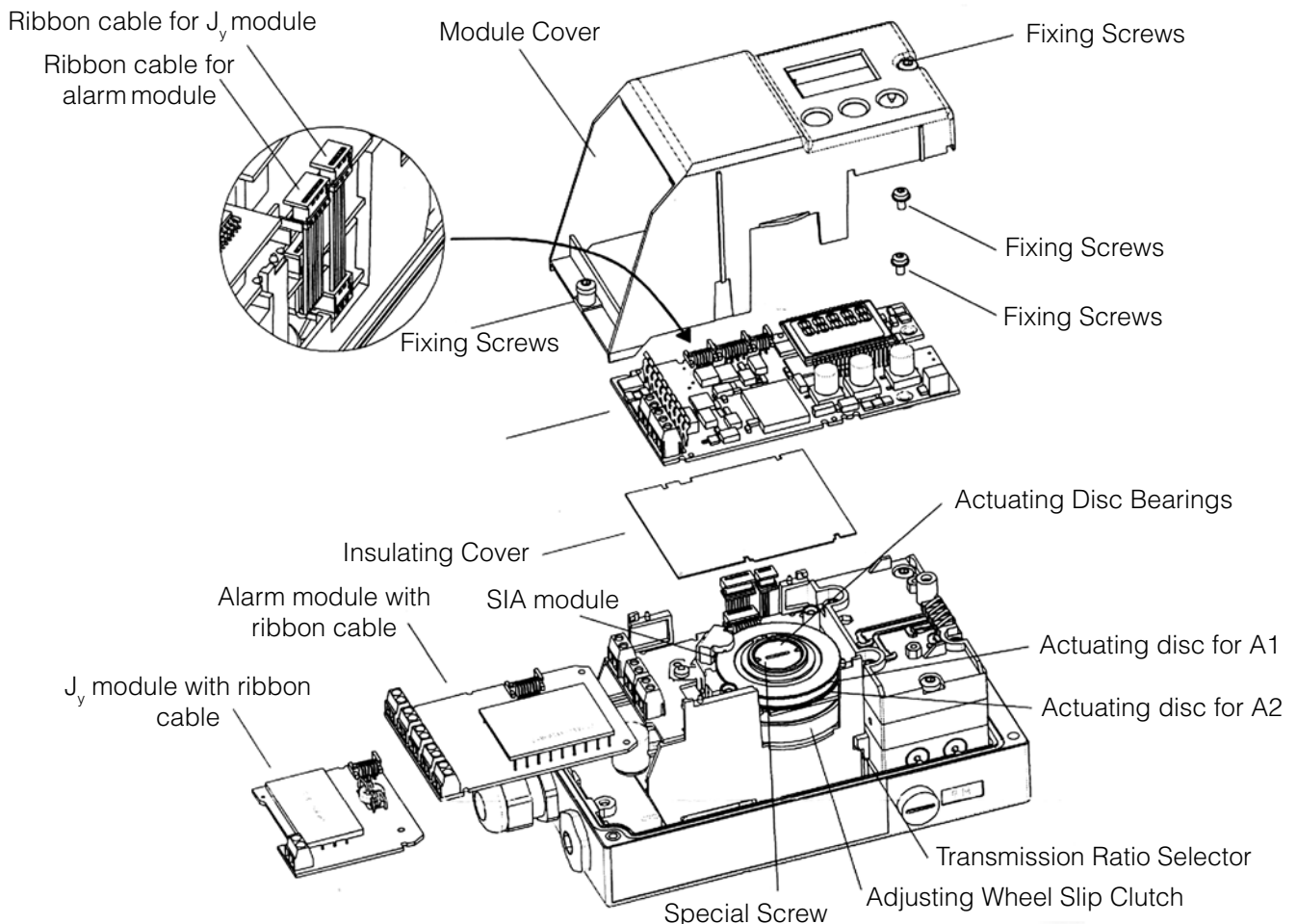

Specifications

Input:

- Signal Range: 2 wire circuit ~ 4-20 mA; 3/4 wire circuit ~ 0 / 4-20 mA
- Load Voltage: 2 wire circuit ~ > 11V with HART; > 10 V without HART
- Auxiliary Voltage: 3/4 wire circuit ~ 18 - 30 V

Output: Up to full air supply pressure

Pneumatic System:

- Air Supply Pressure: 45 psig max for Steriflow Valve actuators)
- Air Capacity: > 5.3 scfm; adjustable
- Standard Consumption: 0.02 scfm independent of air supply pressure

Optional Gauge Block: delivered with two gauges for input air supply and positioning pressure

Control Data:

- Sensing Time A/D Converter: 12.5 ms
- Resolution A/D Converter: <0.05%
- Transmission Error A/D Converter: <0.2%
- Dead Band Controller: adaptive or adjustable, 0.1-10%
- Setting Time Controller: 1.5 - 150

Ambient Temperature: -20 to +175°F

Shock Resistance: 10g

Connections:

- Pneumatic: 1/4" NPT
- Electric: screwed terminals max. 1.5mm², cable union size PG 13

Protection Class: IP 65/NEMA 4X

Weight: 2.86 pounds

Hazardous Location Approvals:

- Basic & Standard HART® protocol unit:
 - FM/CSA: (IS) Class I, Div. 1, Groups ABCD, T6/T5/T4
 - NEC 505: Class I, Zone 2 Group IIC T6/T5/T4.
 - NEC 500: Class I, Div 2 Group IIC T6/T5/T4.
 - EU: II 2G EEx ia/ib IIC T6/T5/T4
- For explosion proof installations (i.e. (XP) Class I, Div. 1), please contact factory for options.

With the HART® option comprehensive sets of maintenance and diagnostic data can be called up directly at the positioner itself:

HART® Protocol

- zero point and range
- actuating speed
- original & current stats
 - Actuator leakage
 - Operating hours
 - Min/max temperatures
 - Valve limit position (i.e. change of stroke length due to seat wear)
- dead band in both directions
- number of alarm reports
- number of directional changes
- total travel

In addition, you may call up data about the controlled actuator:

- instrument number
- type of actuator
- operating mode
- process data
- parameter data

With the SIPROM PS2 Software interface, the current maintenance data can be remotely compared with previous information to quickly detect any deviations so that corrective action can be taken. And, actuator and valve problems can be caught early to allow ample time to schedule repairs.

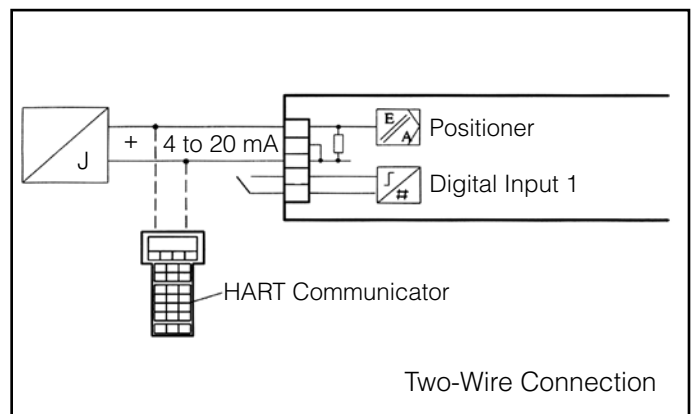

How to Order

1. See Mark 978 Control Valve order grids
2. Select the appropriate base valve model. See models Mark978SP or NSP for an Inline valve. (Sp for Side Mounted Positioner).
3. Select the specific positioner you want in the last digit of the MK978 model number. Choices are available for HART®, Foundation Fieldbus™, models.

Features & Benefits

Features	Benefits
1. Local push-buttons and display.	Save money. Configure the positioner, operate in manual mode, and view diagnostics locally without a handheld or PC.
2. Easy configuration menu with factory presets	Save setup time. Configure only those options that are required. Basic 4-20mA setup in three easy steps.
3. Advanced diagnostics including: deadband changes, stroke & cycle counters, leak detector and more.	Save maintenance time. Focus maintenance efforts by using built-in diagnostics to alarm prior to valve failure.
4. Low bleed, fast response piezo-electric technology.	Save energy. Reduce compressed air usage by virtually eliminating air consumption when the valve is at set-point.
5. Autotune is independent of valve or actuator brand.	Improve control accuracy. The positioner automatically detects and optimizes each valve's unique performance characteristics.
6. User defined tight shut-off for application of full supply pressure.	Save valve trim. Easily set the trigger-point for full sealing pressure to eliminate valve oscillation near the seat.
7. Easy to use double-locking feedback device.	Vibration resistant. Precise flow control in severe environments - to include dirty, dusty, and washdown situations.

Dimensions

